

HORIZONTAL FLUSH BOTTOM RETURN AND SUPPLY

LH-E/200 - 1,200 CFM

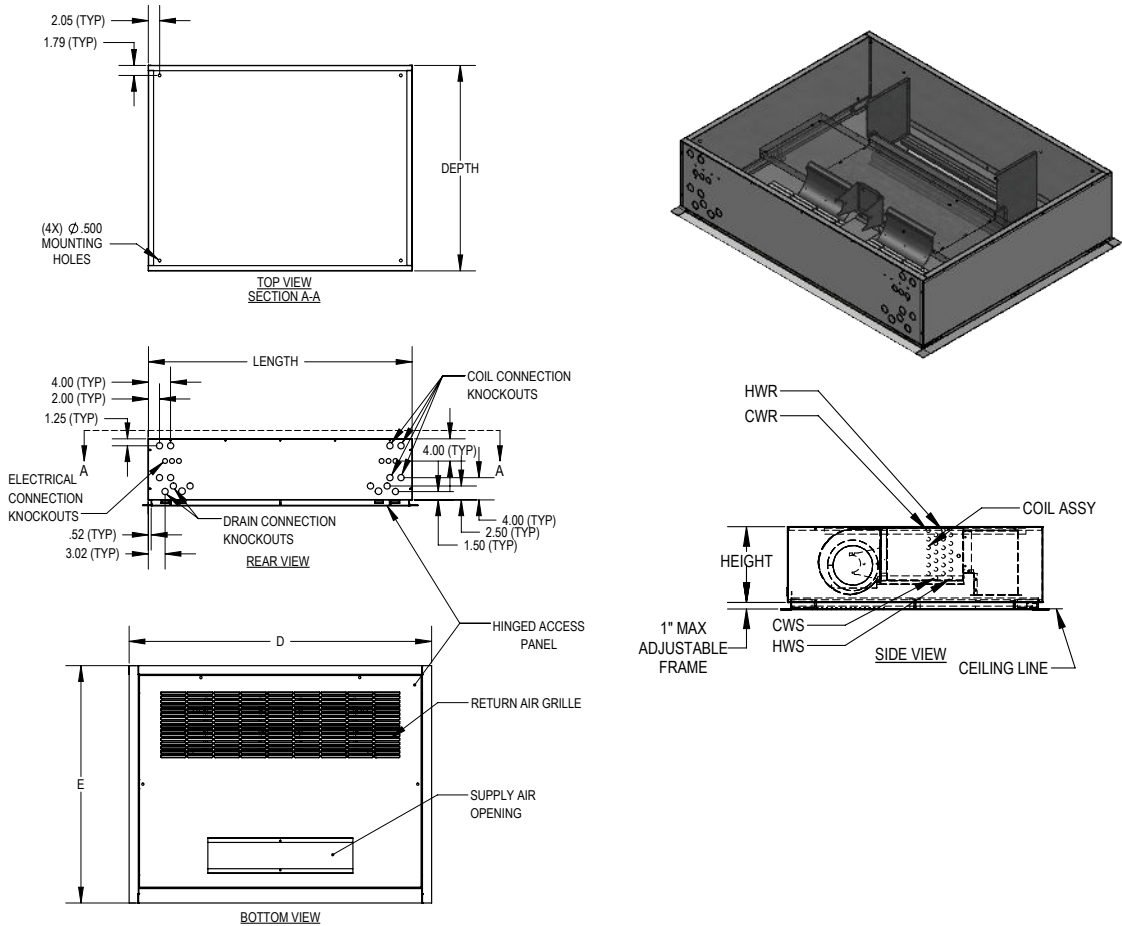

RIGHT HAND SHOWN, LEFT HAND OPPOSITE

UNIT SIZE	OVERALL			FRAME		BLOWERS	FILTER ZSIZE	RA GRILLE	SA GRILLE
	LENGTH	HEIGHT	DEPTH	D	E				
002-003	46.5	11	38	47.5	38.75	1	(2) 11 X 22 X 1	39 x 11	18 x 6
004	46.5	11	38	47.5	38.75	2	(2) 11 X 20 X 1	39 x 11	24 x 6
006	54.5	11	38	55.5	38.75	2	(2) 11 X 24 X 1	47.5 x 10.5	32 x 6
008	54.5	13	44	55.5	44.75	2	(2) 11 X 24 X 1	43.5 x 10.5	32 x 8
010	68.5	13	44	69.5	44.75	2	(2) 11 X 27 X 1	52 x 10.75	36 x 8
012	68.5	13	44	69.5	44.75	2	(2) 11 X 27 X 1	52 x 10.75	42 x 8

- Right hand unit shown, left hand unit opposite.
- Coil connections determined by facing the supply air opening.
- Electrical junction box is located on the same side as the coil connections.
- Unit must be installed level and condensate drain lines should be trapped.
- Drain pan is powder coated epoxy with a 1/8" thick Elastomeric insulation and has 3/4" NPT primary and secondary drain connections.
- Entire cabinet, scroll and blower wheel are heavy gauge, galvanized steel.
- Coil connections: 1/2" CW and HW on 002-003.